

Perspective View

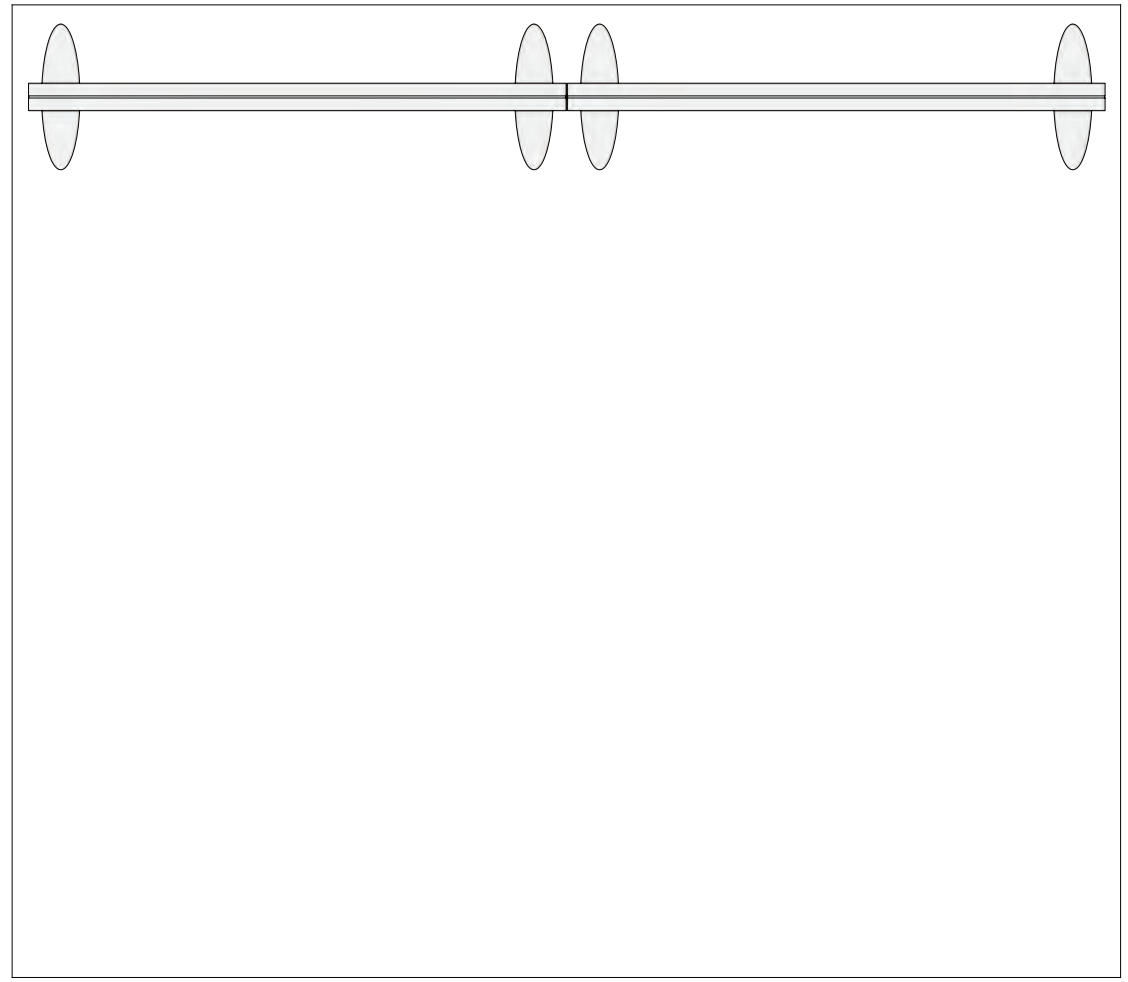

12'

Plan View

# ***SETUP INSTRUCTIONS***

## General Setup Instructions

- Read entire setup instruction manual prior to unpacking parts and pieces.
- The setup instructions are created specifically for this configuration.
- Setup instructions are laid out sequentially in steps, including exploded views with detailed explanation for assembly.

## Cleaning & Packing

- For Cleaning Metal, Plex, & Laminate Parts: Use a **MILD NON-ABRASIVE** cleanser and soft cloth/paper towel to clean all surfaces.
- Keep exhibit components away from heat and prolonged sun exposure.
- **Heat and UV exposure will warp and fade components.**
- Retain all provided Packing Materials. All provided packing materials are for ease of repacking & component protection.

## Disassembly

- For loss prevention, tighten all set screws and locks during disassembly.

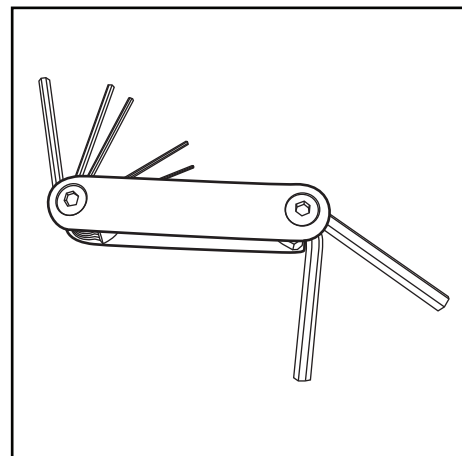

Hex Tool - Essential for Assembly

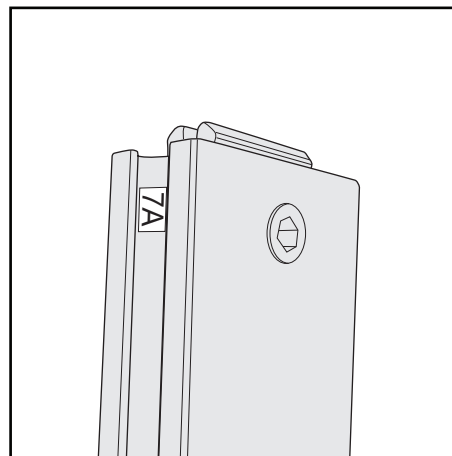

Part Identification - Numbering

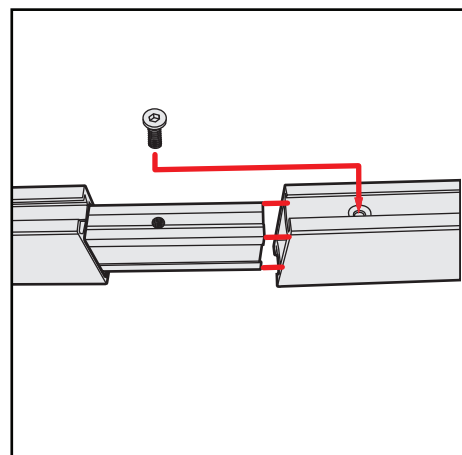

Spline Connection

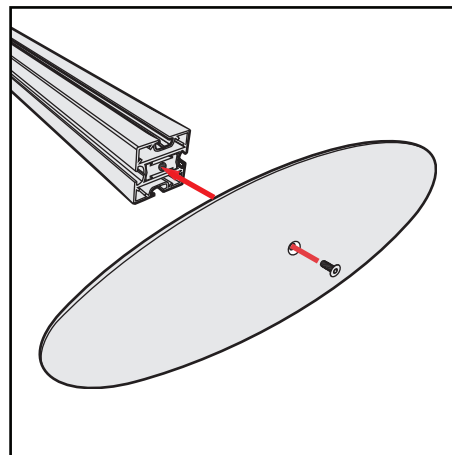

Base Plate & Extrusion Connection

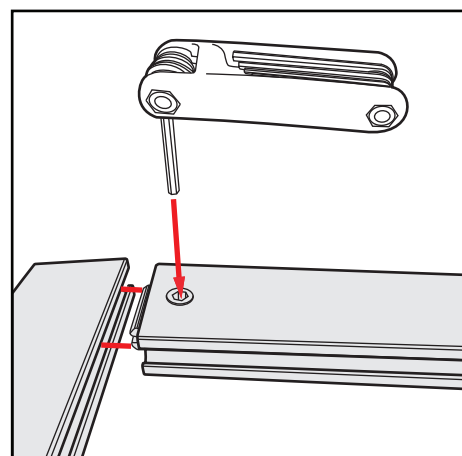

Extrusion & Lock Connection

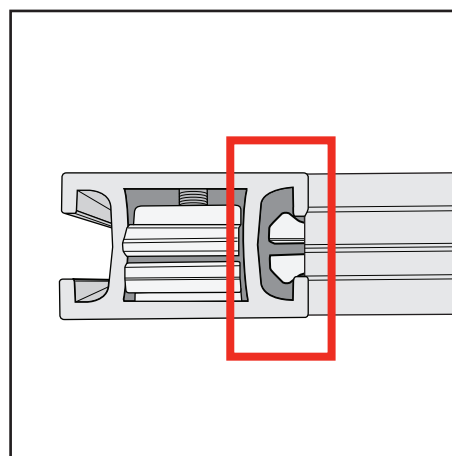

Engaged Lock



# WARNING

DO NOT USE POWER TOOLS



LADDERS OR LIFTS  
MAY BE REQUIRED

ALL CONNECTIONS MUST  
BE TIGHTLY SECURED



## SEG Graphic Installation

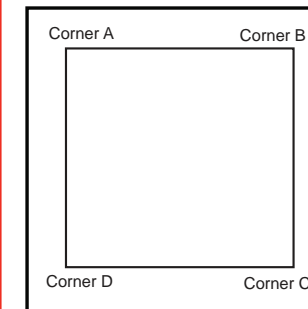

It is important to first insert graphic into each alternate corner, then to the sides of the frame. If this is not done, graphic will not fit into the frame correctly.

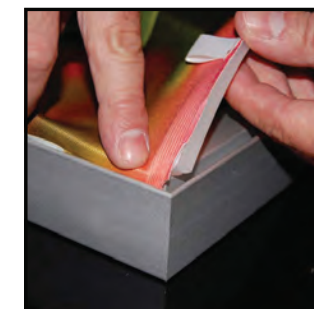

Step 1  
Insert corner A. Turn edge of graphic so silicon welt is perpendicular to face of graphic. Insert narrow side of welt with fabric to outside into the channel. Repeat for other side of this corner.



Step 2  
Repeat Step 1 for opposite corner C, then insert corner B, followed by corner D, to complete the installation of the corners.



Step 3  
Once all corners are inserted, press one silicon edge into channel from corners and work toward the center. Make sure welt is fully inserted into channel. Continue until all sides are done. Smooth out edges of graphic.

### Graphic Removal



To remove the graphic from the frame, locate the fabric pull tab. Gently pull up on the tab to remove the fabric.

### Top View of Each Level

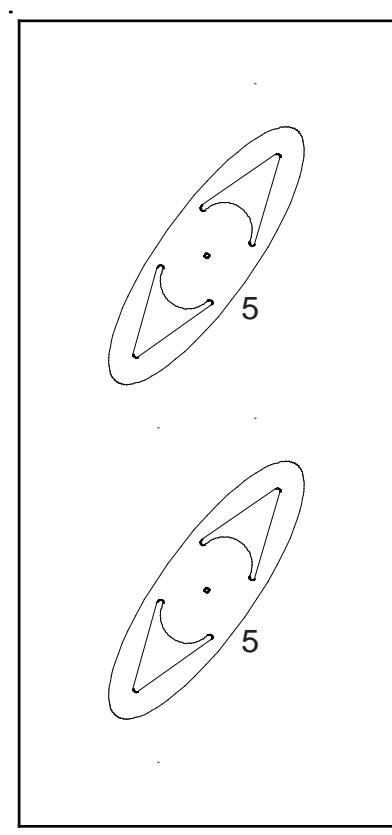

Level 1 (Bottom Level)

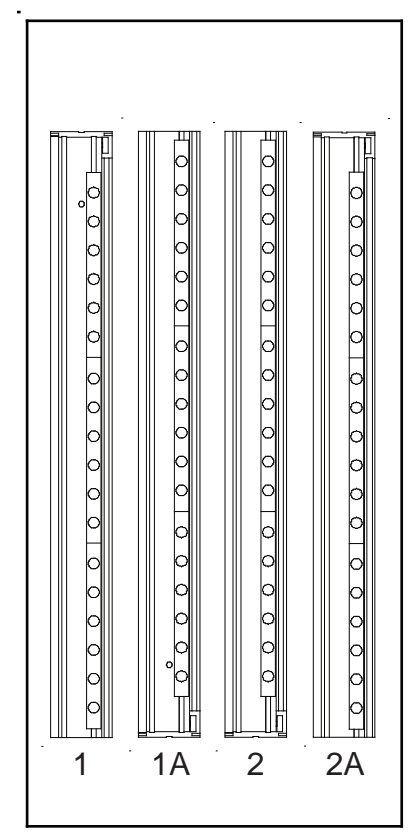

Level 2

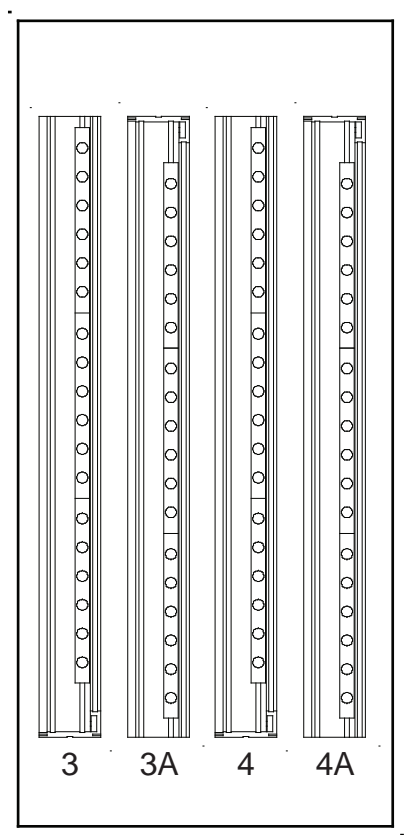

Level 3

Graphics

Setup Hardware

### Top View of Each Level

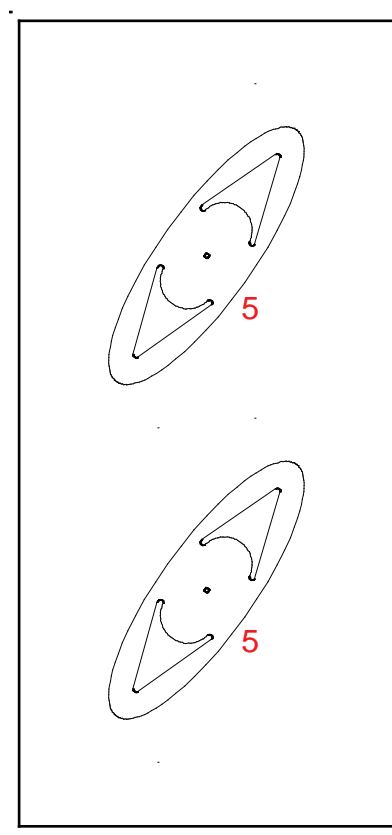

Level 1 (Bottom Level)

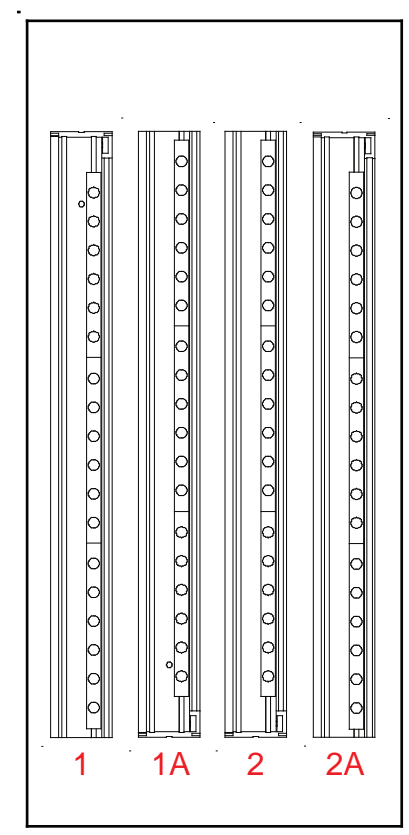

Level 2

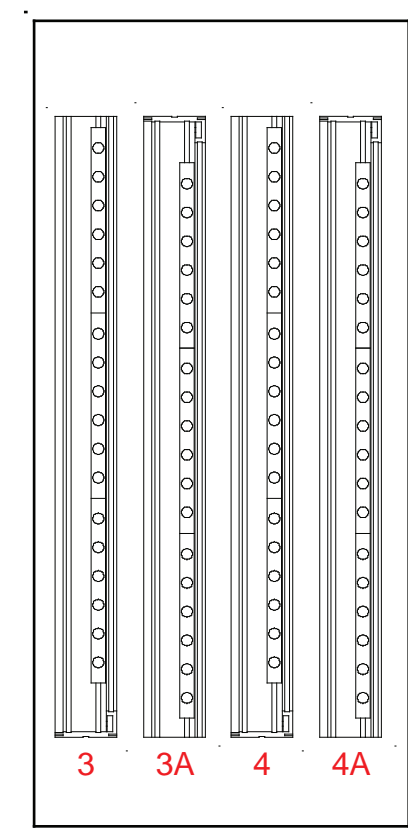

Level 3

Graphics

Setup Hardware

Item	Qty.	Description
1,1A	1,1	42" CEI110 Horizontal Extrusion
2,2A	1,1	42" CEI110 Horizontal Extrusion
3,3A	1,1	43.141" CEI110 Vertical Extrusion
4,4A	1,1	43.141" CEI110 Vertical Extrusion
5	2	Base Plate

Steps:

- 1) Assemble extrusions together. See **Tool-less Connector** details.
- 2) Connect lighting cords and attach transformers. See **Light to Light Connection** and **Light to Transformer Connection** details.
- 3) Attach base plates to horizontal [5] using bolts, washers, and wing nuts.
- 4) Install SEG fabric to front of assembled backwall and blocker fabric to back. See reverse side for SEG Graphic Installation instruction.

**\* Tool-less Spline Connector**

1. Place extrusions end-to-end.
2. Slide tool-less connectors across seam of extrusions.
3. Tighten all knobs to secure connection.

**\* Tool-less Corner Connector**

1. Slide extrusion onto Corner Connector.
2. Tighten all knobs to secure connection.

*Keep corner connectors attached to horizontal extrusions.*

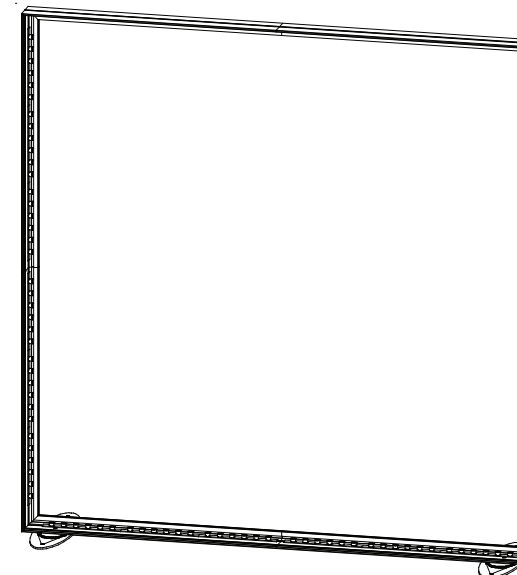
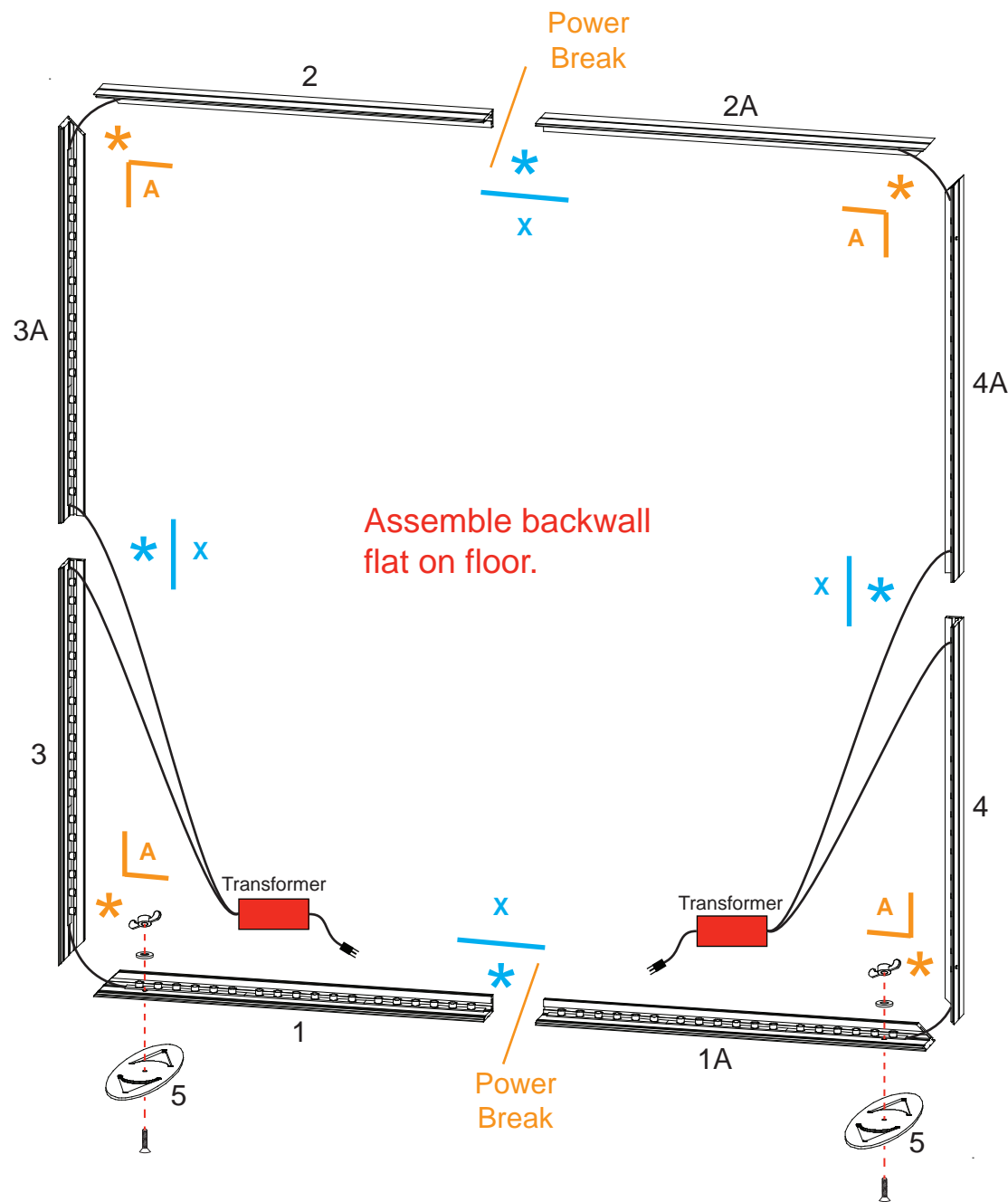

Completed Assembly

**Light to Light Connection**

**Light to Transformer Connection**

Maximum of 14 lights per transformer.

Item	Qty.	Description
1,1A	1,1	42" CEI110 Horizontal Extrusion
2,2A	1,1	42" CEI110 Horizontal Extrusion
3,3A	1,1	43.141" CEI110 Vertical Extrusion
4,4A	1,1	43.141" CEI110 Vertical Extrusion
5	2	Base Plate

Steps:

- 1) Assemble extrusions together. See **Tool-less Connector** details.
- 2) Connect lighting cords and attach transformers. See **Light to Light Connection** and **Light to Transformer Connection** details.
- 3) Attach base plates to horizontal [5] using bolts, washers, and wing nuts.
- 4) Install SEG fabric to front of assembled backwall and blocker fabric to back. See reverse side for SEG Graphic Installation instruction.

**\* Tool-less Spline Connector**

1. Place extrusions end-to-end.

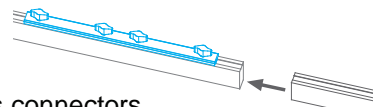

2. Slide tool-less connectors across seam of extrusions.

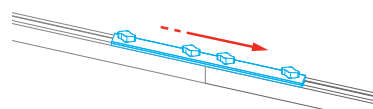

3. Tighten all knobs to secure connection.

**\* Tool-less Corner Connector**

1. Slide extrusion onto Corner Connector.
2. Tighten all knobs to secure connection.

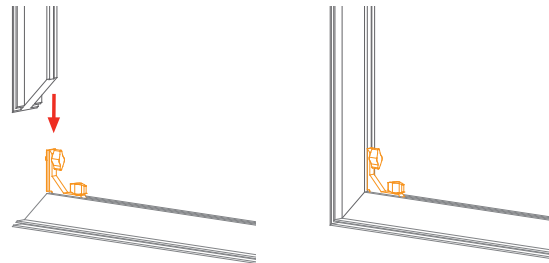

Keep corner connectors attached to horizontal extrusions.

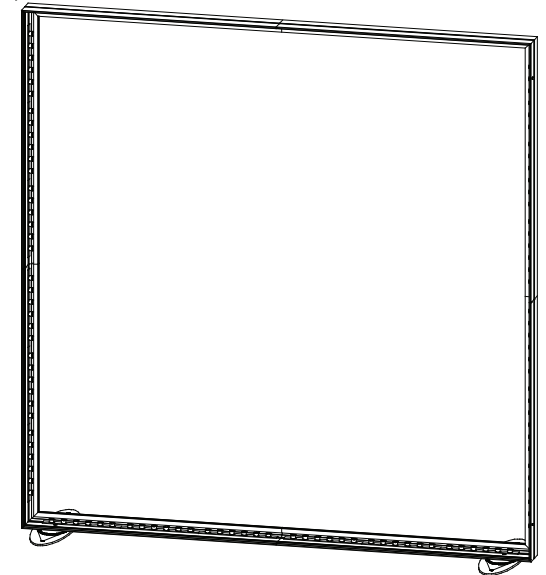
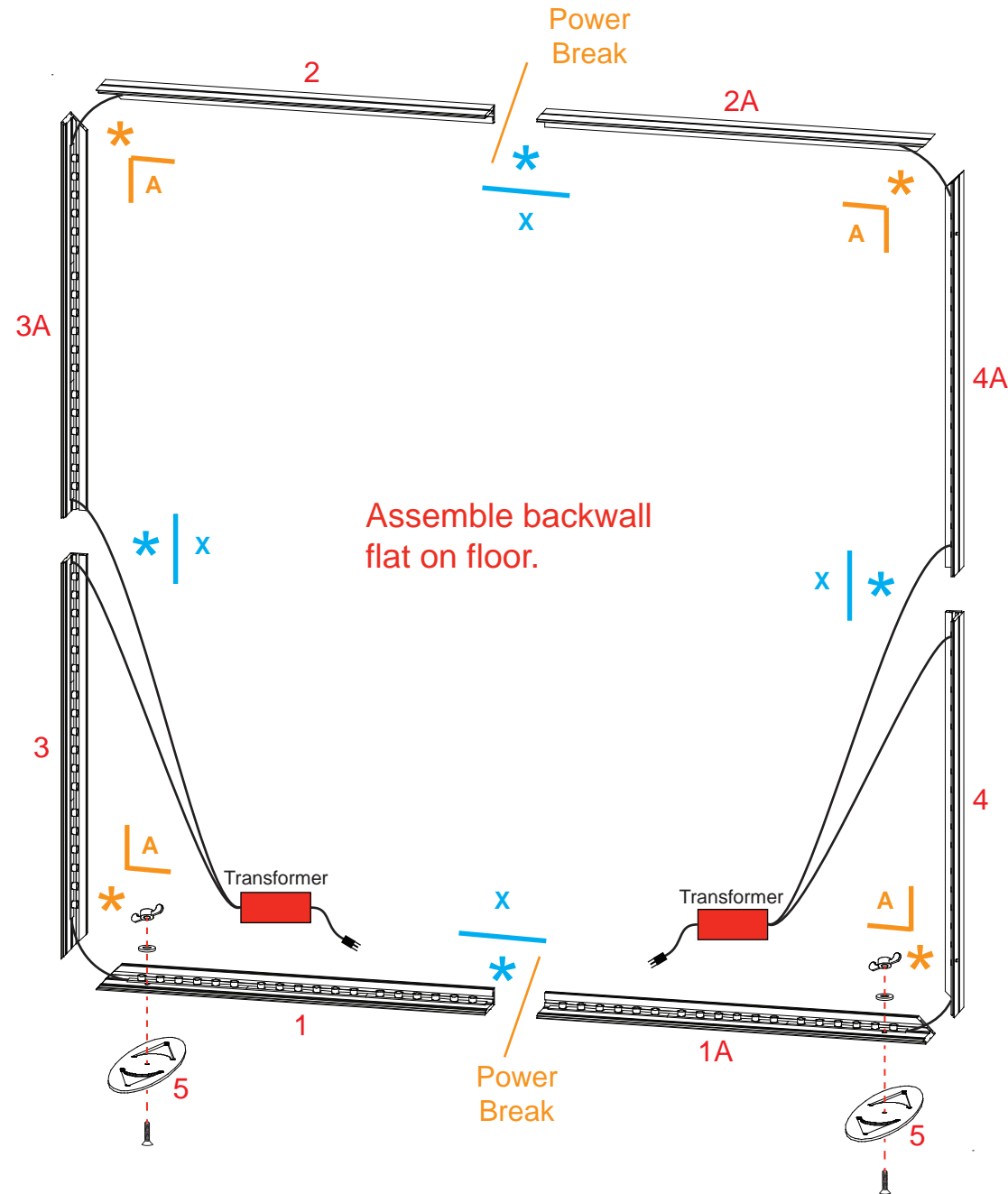

Completed Assembly

**Light to Light Connection**

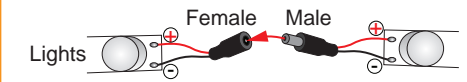

**Light to Transformer Connection**

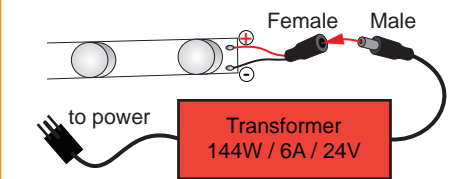

Maximum of 14 lights per transformer.

Item	Qty.	Description
1~5	10	Lite Box Frame - Left [Black]
1~5	10	Lite Box Frame - Right [Red]

- Steps:
1. Assemble extrusions together for Left and Right Frames. See Left and Right Assembly on following pages.
  2. Connect frames V31 connector extrusion. Press/snap into place in channels of lite box extrusions between frames as shown. Lock into place as needed by tightening with tiny allen wrench at set screws along extrusion. See V31 Connection.

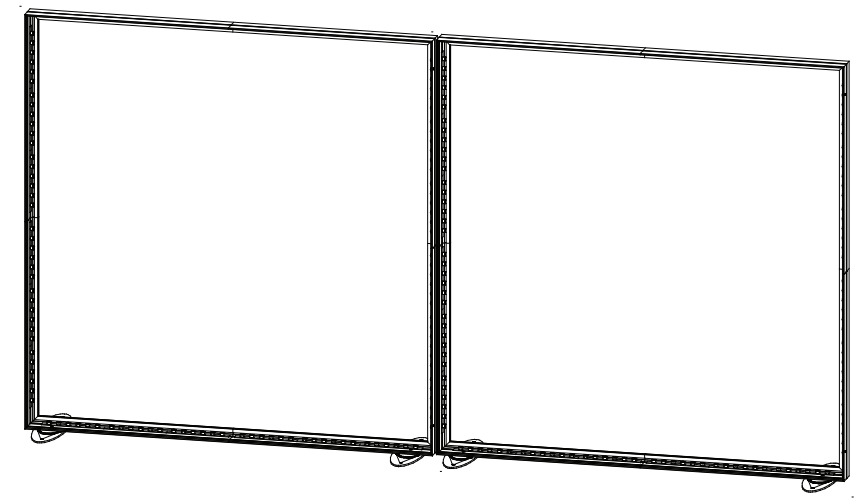

Completed Assembly

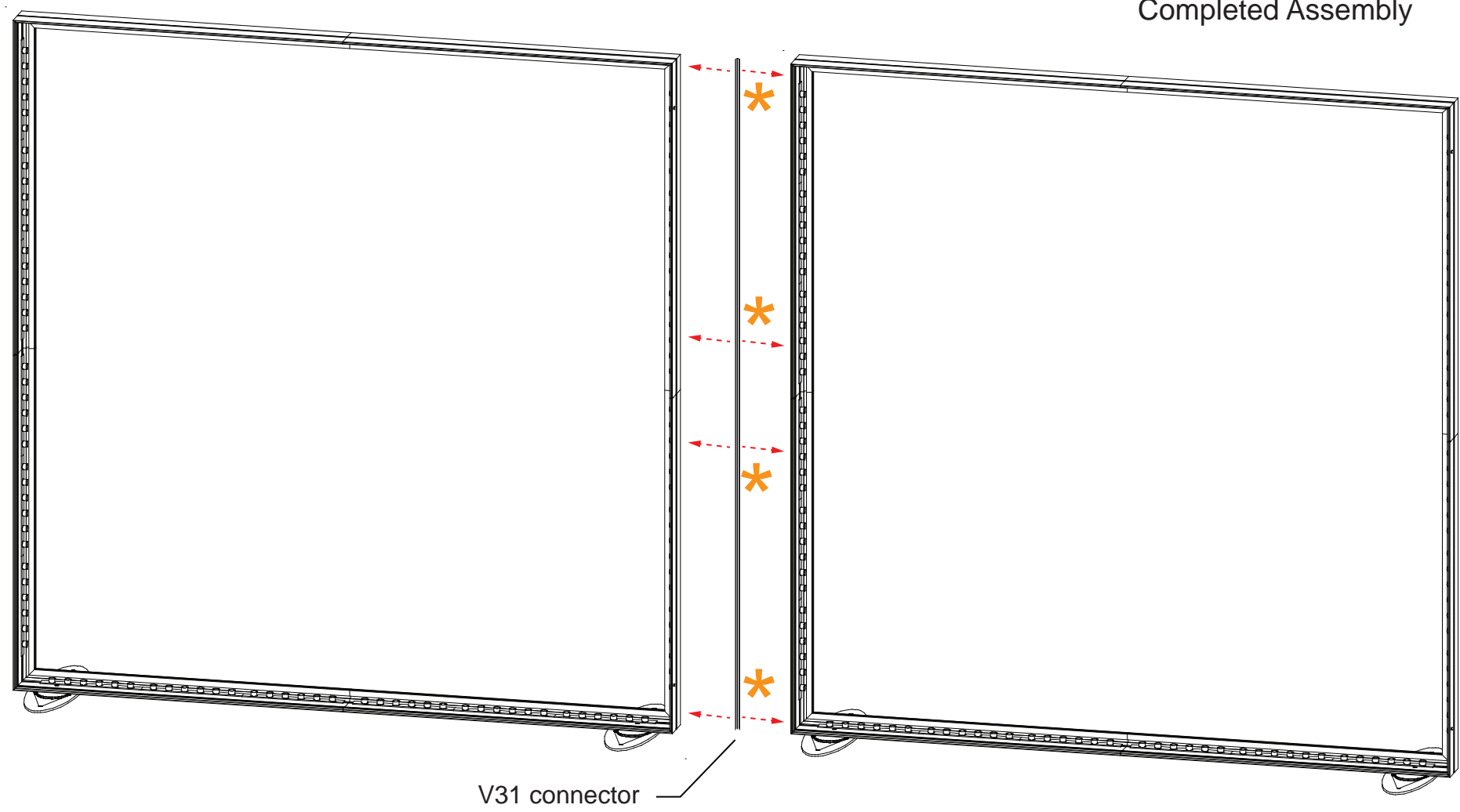

CEI110 to CEI110

**\* V31 Connection**

Slide V31 connector into channels of vertical extrusions.

Tighten set screws to secure.